

Please take time to read and follow the instruction below.

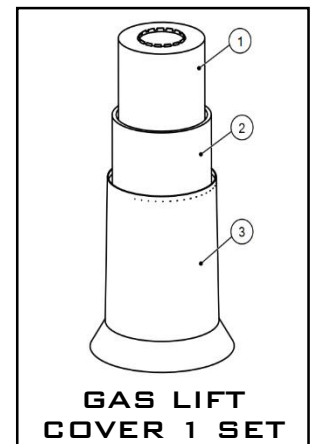
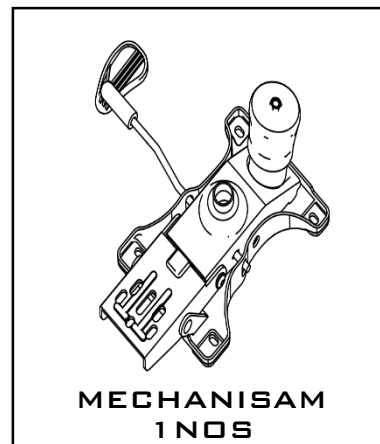
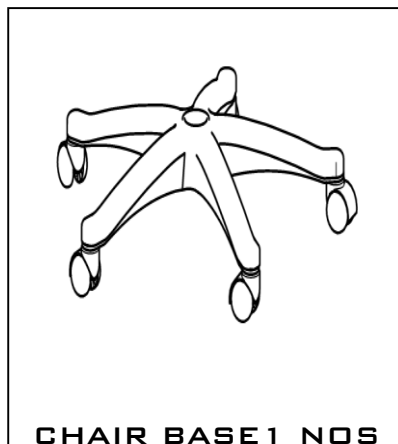
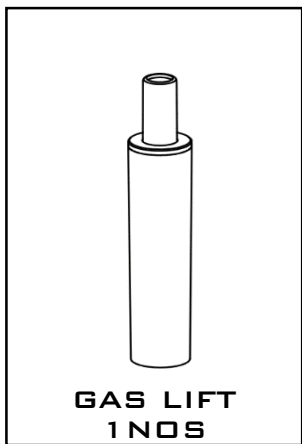
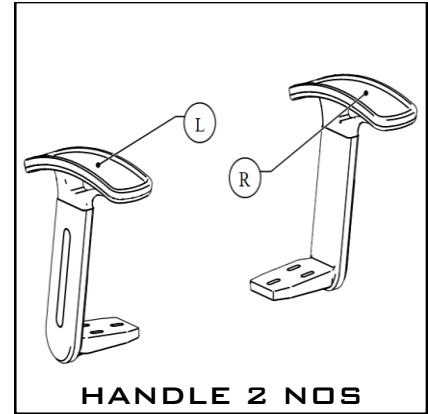
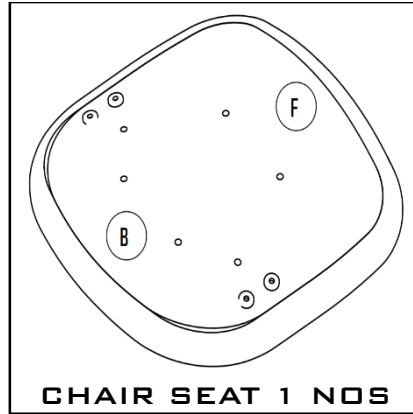
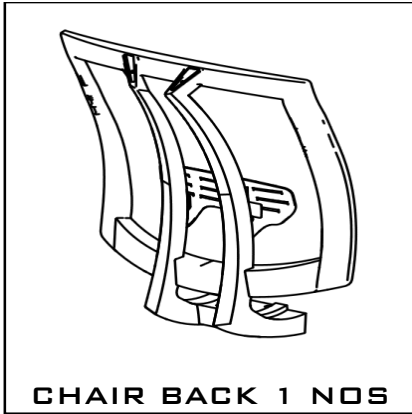

### Attention:

- Check that you have all parts and hardware before assembly.
- Parts apparently missing are often found in the packaging material.
- Hardware are already fitted into component.
- Use sticker as a reference for easy assembly.
- Do not tighten screw fully until you have completed assembly.
- Do not use this product unless all bolts are firmly secured.
- Check that all bolts and screws are securely tightened at least every 4 months.

# For high back Chair

Fix the Head rest with Chair back as shown in image

(Note: For medium back head rest not available)

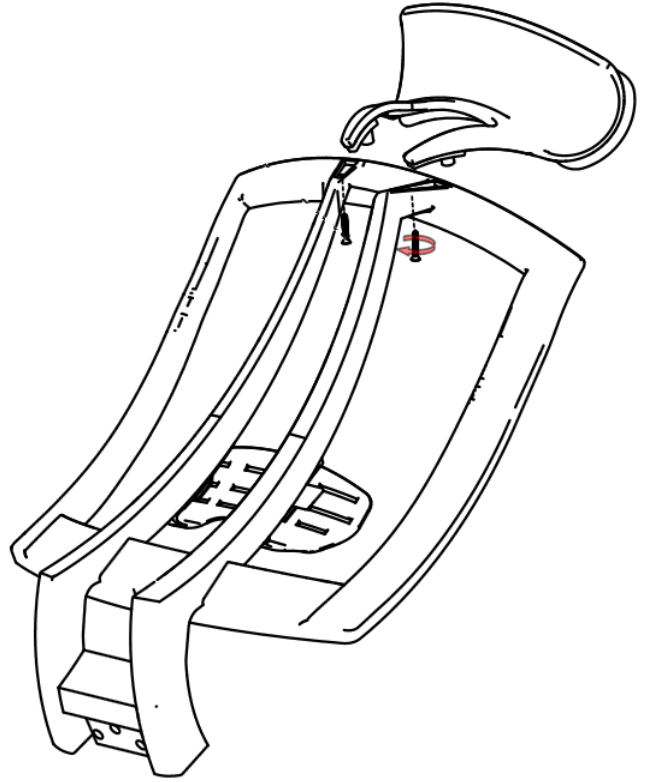

## Step 1

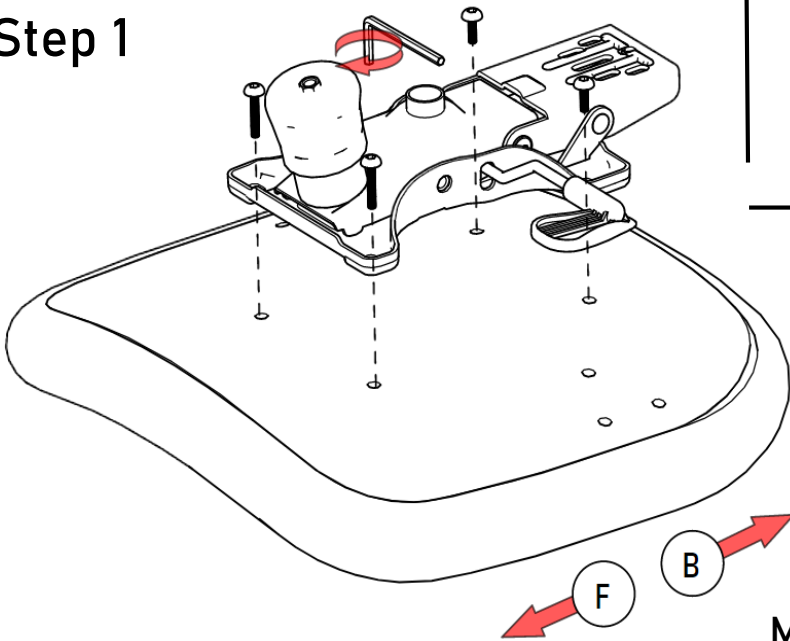

Place seat as shown in image than fit mechanism  
(Note: focus on right bottom corner annotation F-front B-

Make sure direction of arrow on mechanism is toward the seat front

Match the sticker before fitting

## Step 2

Place the handle as shown in image than fit with the help of Allen screw and Allen key

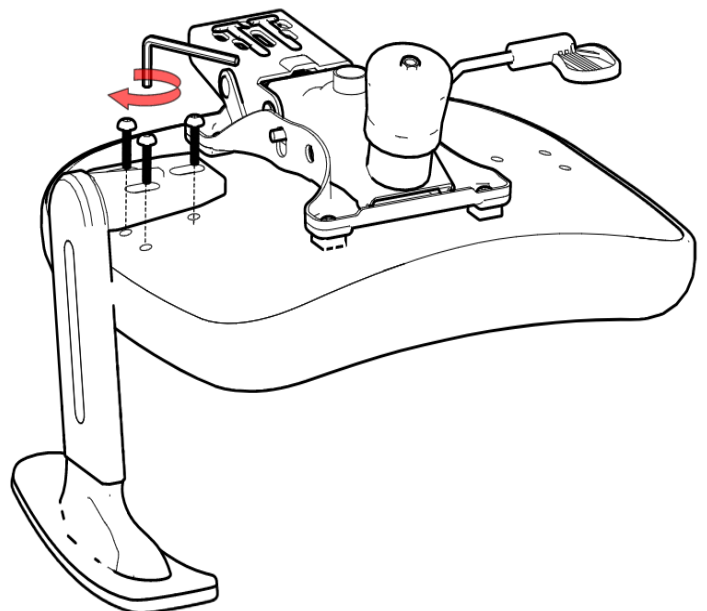

Match the sticker before fitting

Step 2 follow for fitting other side of handle

### Step 3

Fix the chair back with the mechanism as shown in image

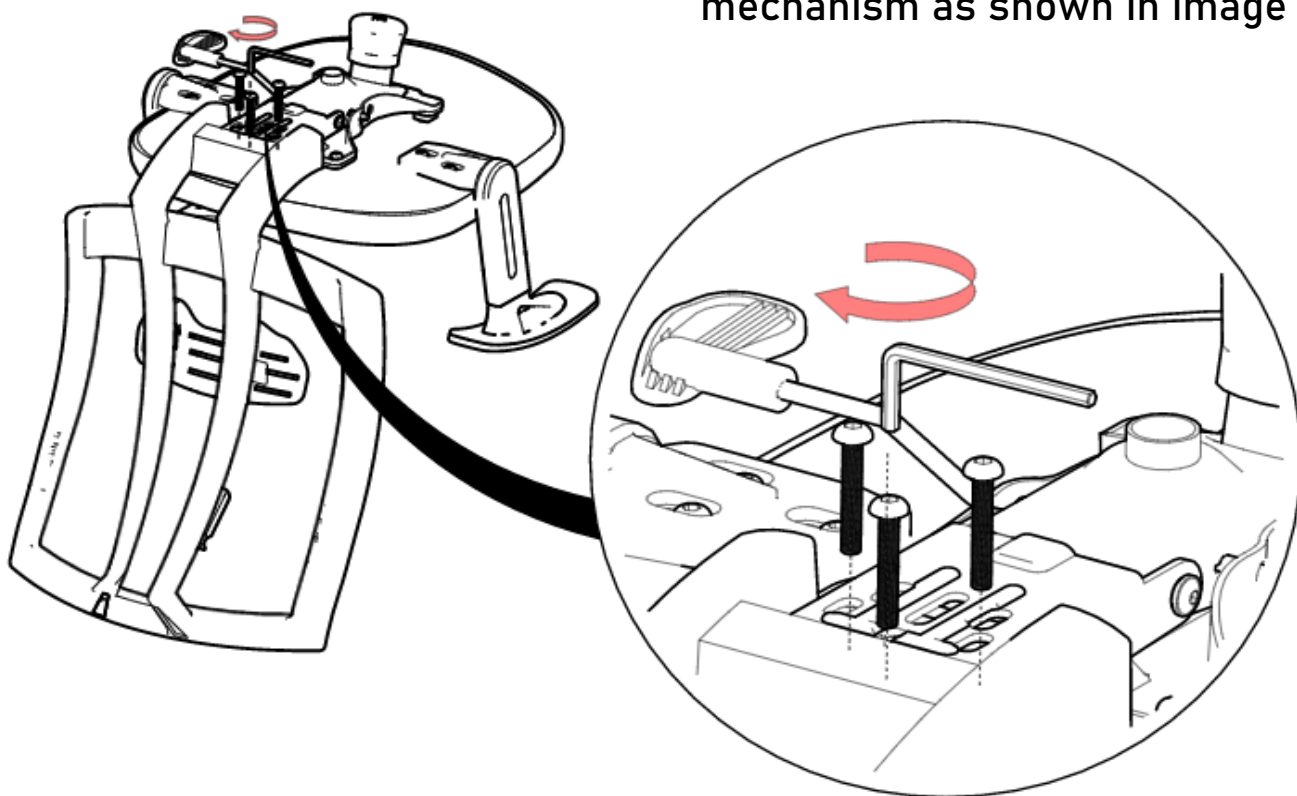

### Step 4

Place the chair base on floor

Cover the gas lift with the gas lift cover and fix it to the chair base

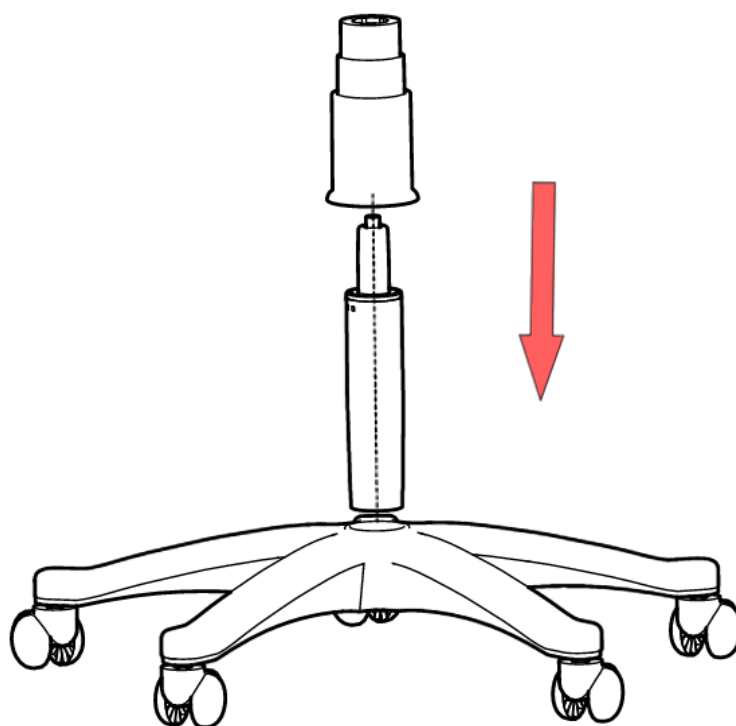
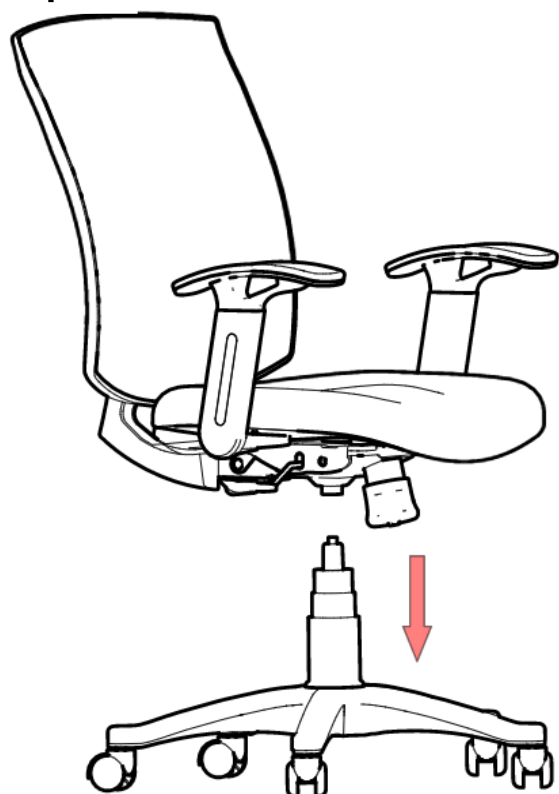

Attach the seat and back assembly of chair to the base assembly  
(Note: Check the chair to ensure proper fixing)



Furniture & more

# ASSEMBLY MANUAL



\*Terms and condition Apply.

Contact us: +91-9904304466  
10:00 AM to 5:30 PM (Monday-Friday)  
shop.hofindia.com

Model: F509-510