

Please take time to read and follow the instruction below.

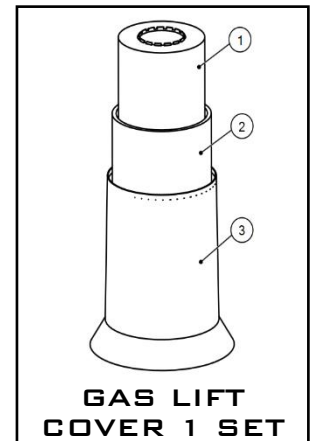
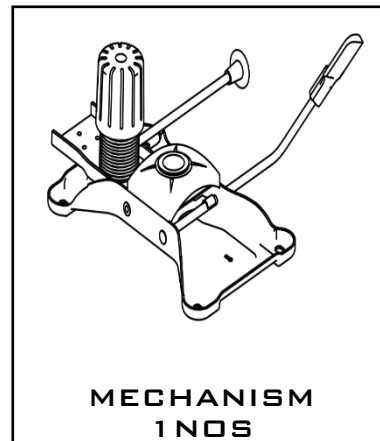
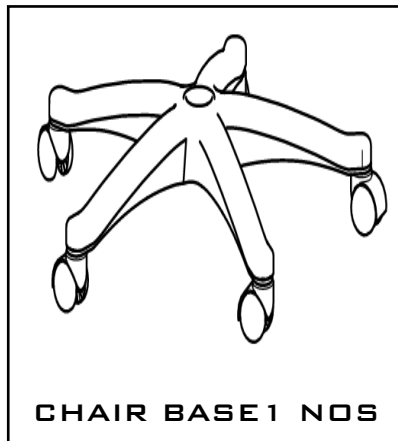
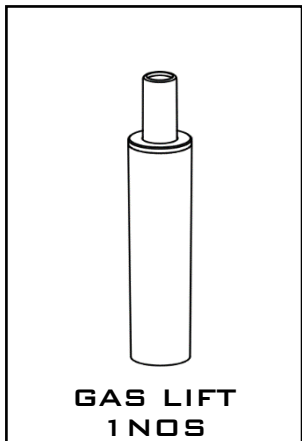
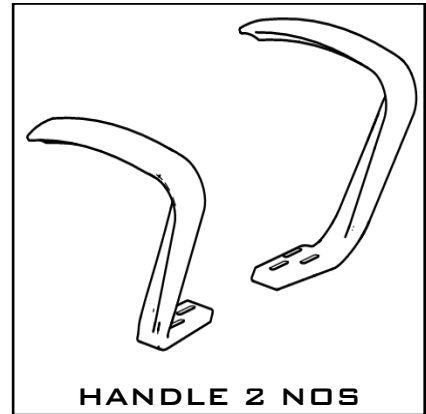
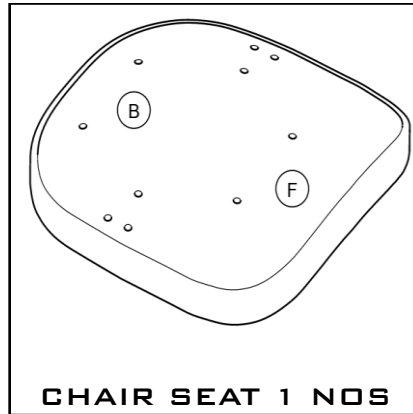
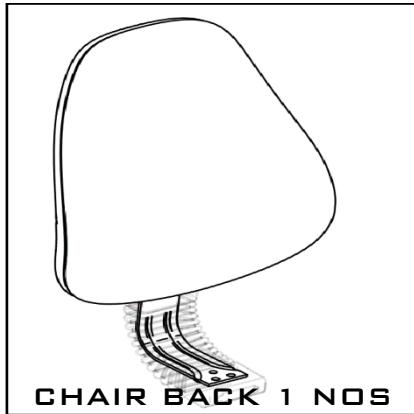

## Attention:

### **Hardware are already fitted into component**

- Find the Allen key in the bag of Assembly manual.
- Parts apparently missing are often found in the packaging material.
- Use sticker as a reference for easy assembly.
- Do not tighten screw fully until you have completed assembly.
- Do not use this product unless all bolts are firmly secured.
- Check that all bolts and screws are securely tightened at least every 4 months.

## Step 1

Place seat as shown in image than fit mechanism  
(Note: focus on right bottom corner annotation  
**F**-front & **B**-back).

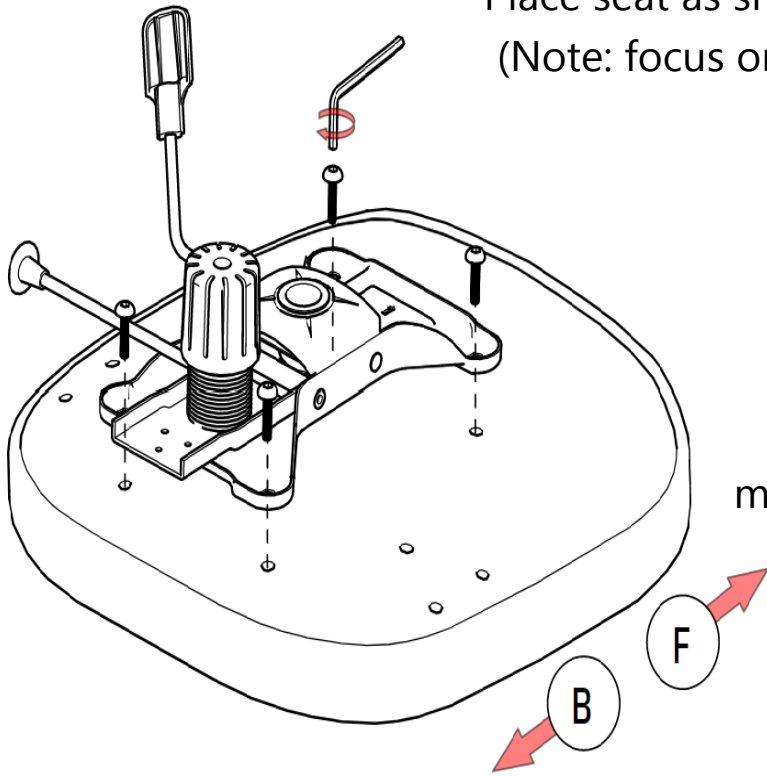

Match the sticker before fitting.

Make sure direction of arrow on  
mechanism is toward the seat front.

## Step 2

Place the handle as shown in image  
than fit with the help of Allen screw  
and Allen key.

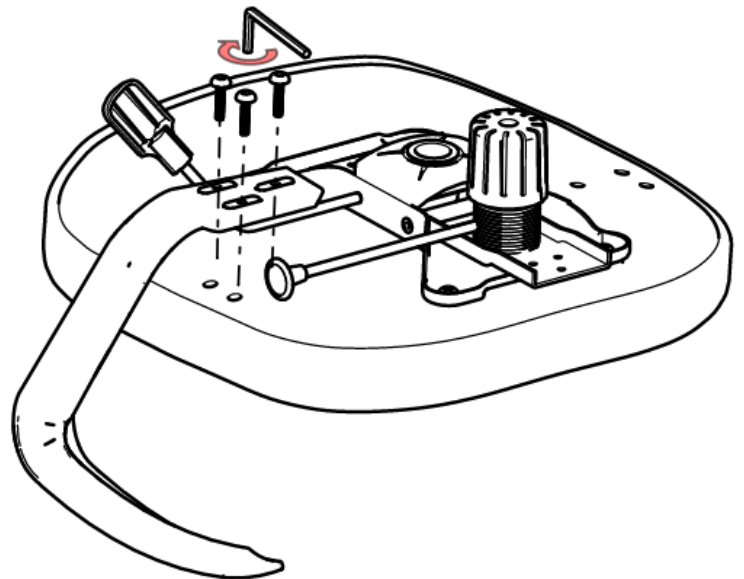

Match the sticker before fitting.

Step 2 follow for fitting other side of handle.

### Step 3

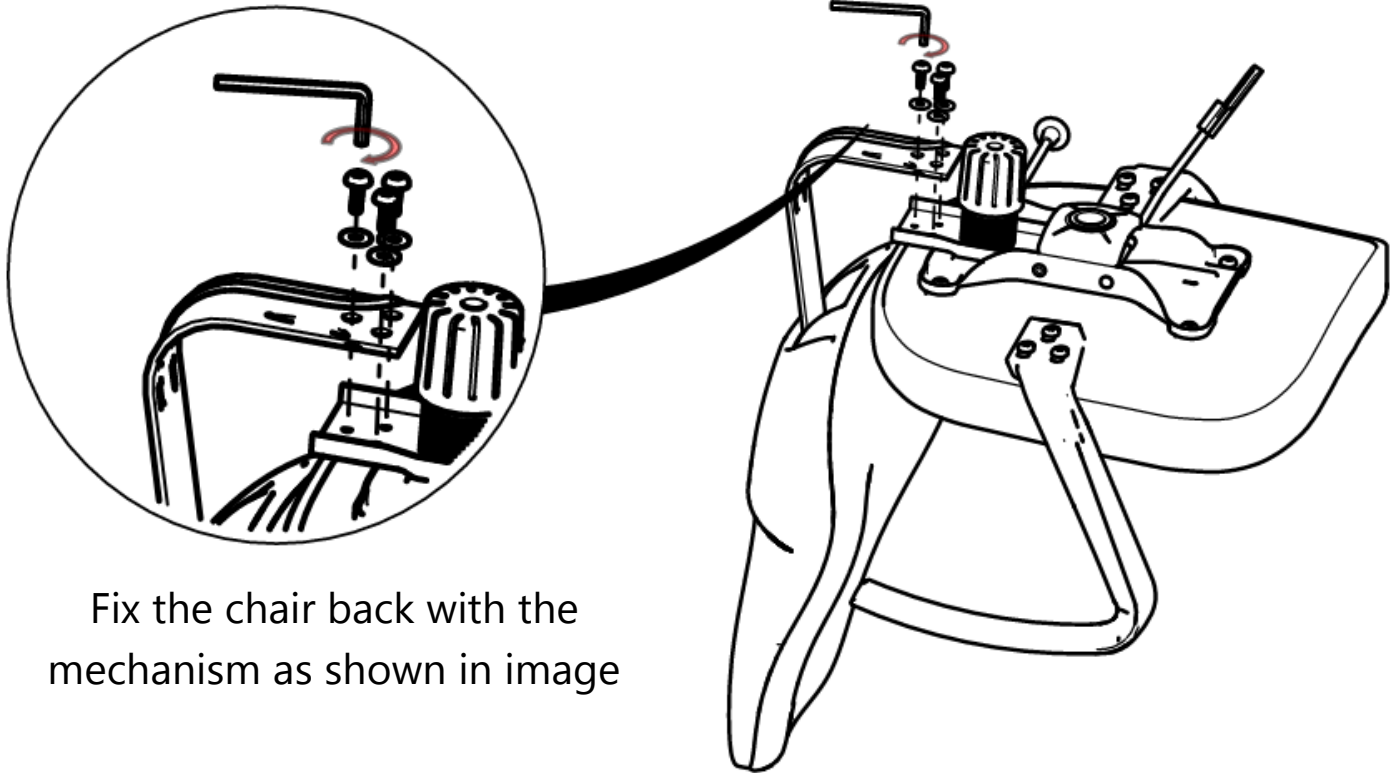

Fix the chair back with the mechanism as shown in image

### Step 4

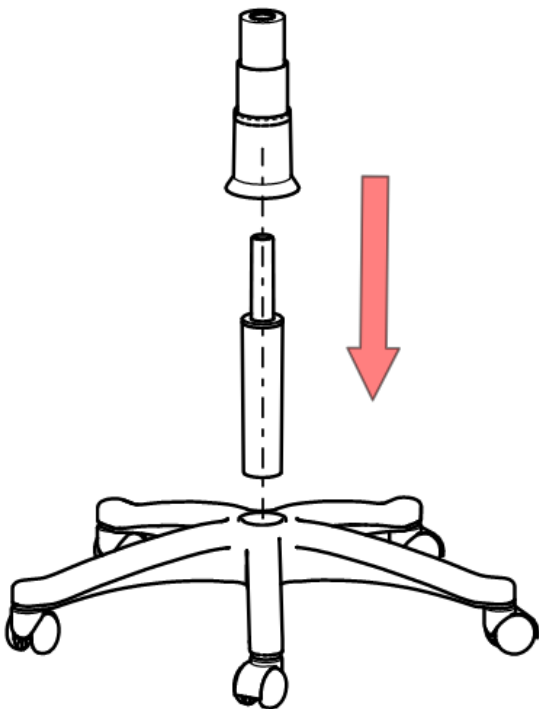

Place the chair base on floor  
Cover the gas lift with the gas lift cover and fix it to the chair base

### Step 5

Attach the seat and back assembly of chair to the base assembly  
(Note: Check the chair to ensure proper fixing)

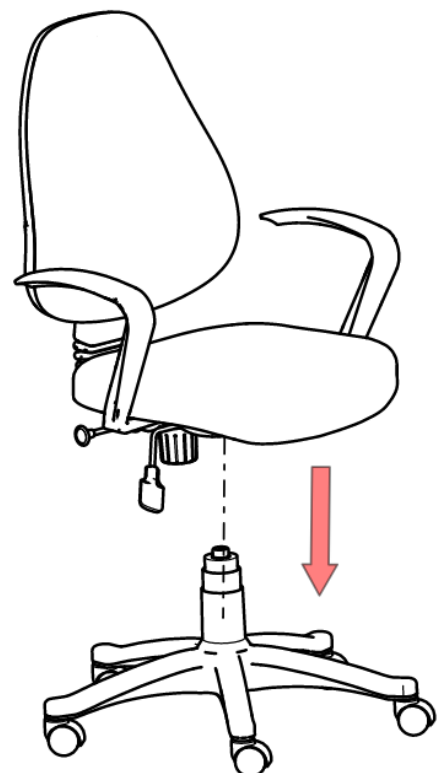



Scan the QR Code for watching  
chair assembly instruction



# ASSEMBLY MANUAL



Contact us: +91-9904304466  
10:00 AM to 5:30 PM (Monday-Friday)

[shop.hofindia.com](http://shop.hofindia.com)

**Model: F-502**